



TOPSTAR TECHNOLOGY INDUSTRIAL CO., LIMITED

产品规格书

Product Specification Sheet

TOP-SFP-1.25G-80D

RoHS Compliant 1.25Gbps 1550nm 80KM Single mode Optical Transceiver



E-MAIL: lisa@topsfp.com





Product Features

- Transceiver unit with independent
- DFB laser transmitter and PIN photo-detector
- Dual Data-rate of 1.25Gbps/1.0625Gbps Operation
- Up to 80KM transmission distance on 9/125μm SMF
- Standard serial ID information compliant with SFP MSA
- SFP MSA package with duplex LC connector
- Digital Diagnostic Monitor Interface
- Very low EMI and excellent ESD protection
- +3.3V single power supply
- Wide operating temperature range
- RoHS compliant
- Operating temperature
- Commercial: 0°C to +70°C Extended: -10°C to +80°C Industrial: -40°C to +85°C

Applications

- Switch/Router
- SAN/Server
- Other optical transmission systems

Standard

- SFP MSA (Version Sept.14 2000) compliant
- SFF-8472 (Rev 9.3, Aug. 2002) Digital Diagnostic Monitoring Interface for Optical Transceivers compliant
- IEEE 802.3z compliant
- ANSI specifications for Fiber Channel compliant
- Telcordia GR-468-CORE compliant



Description

TOP-SFP-1.25G-80D optical transceivers are designed for GE/1 x FC optical interface for data communications with single mode fiber (SMF), and multimode fiber (MMF) as well. They operate at both 1.25Gbps for GE and 1.0625Gbps for 1xFC. The transceiver designs are optimized for high performance and cost effective to supply customers the best solutions for datacom applications.

Functional Diagram

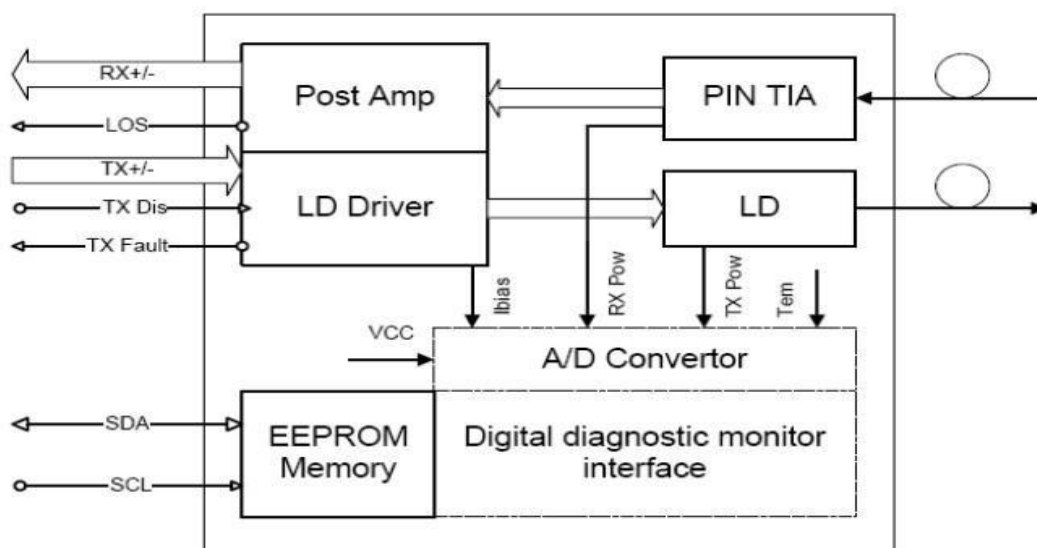

Absolute Maximum Ratings

Parameter	Symbol	Min	Ma x	Unit	Notes
Supply Voltage	Vcc	-0.5	3.60	V	
Storage Temperature		-40	85	°C	
Relative Humidity		5	95	%	

Note: Stress in excess of the maximum absolute ratings can cause permanent damage to the module.



General Operating Characteristics

Parameter		Symbol	Min.	Typ.	Max.	Unit	Notes
Data Rate	Gigabit Ethernet			1.25		Gb/s	
	Fiber Channel			1.0625			
Supply Voltage		Vcc	3.1	3.3	3.5	V	
Supply Current		Icc			300	mA	
Operating Case Temperature		Tc	0		70	°C	
			-10		80		
			-45		85		

Electrical Input/Output Characteristics

• **Transmitter**

Parameter		Symbol	Min.	Typ.	Max.	Unit	Notes
Diff. Input Voltage Swing			300		1800	mVpp	1
Tx Disable Input	H	V _{IH}	2.0		Vcc+0.3	V	
	L	V _{IL}	0		0.8		
Tx Fault Output	H	V _{OH}	2.0		Vcc+0.3	V	2
	L	V _{OL}	0		0.8		
Input Diff. Impedance		Zin		100		Ω	

• **Receiver**

Parameter		Symbol	Min.	Typ.	Max.	Unit	Notes
Diff. Output Voltage Swing			400		1000	mVpp	3
Rx LOS Output	H	V _{OH}	2.0		Vcc+0.3	V	2
	L	V _{OL}	0		0.8		

Note 1) TD+/- are internally AC coupled with 100Ω differential termination inside the module.

Note 2) Tx Fault and Rx LOS are open collector outputs, which should be pulled up with 4.7k to 10kΩ



resistors on the host board. Pull up voltage between 2.0V and Vcc+0.3V.
 Note 3) RD+/- outputs are internally AC coupled, and should be terminated with 100Ω (differential) at the user SERDES.

LOS De-assert	Pd			-27	dBm
LOS Hysteresis	Pd-Pa	0.5		6	dB

Optical Characteristics

• Transmitter

Parameter	Symbol	Min.	Type	Max.	Unit	Notes
Ave. Output Power (Enable)	Po	0		5	dBm	1
Total Jitter	1.25G			0.431	UI	
Extinction Ratio	ER	9			dB	1
Rise/Fall Time (20%-80%)	Tr-Tf			0.26	ns	2
Wavelength Range		1530	1550	1570	nm	
Spectral Width (RMS)				1	nm	
Output Optical Eye	Compliant with IEEE802.3 z (class 1 laser safety)					

• Receiver

Parameter	Symbol	Min.	Type	Max.	Unit	Notes
Operating Wavelength		1270		1610	nm	
Sensitivity	Pimin			-25	dBm	3
Min. Overload	Pimax	-3			dBm	3
Total Jitter	1.25G			0.749	UI	
LOS Assert	Pa	-38			dBm	

Note 1) Measured at 1250 Mb/s with PRBS 27 – 1 NRZ test pattern.

Note 2) Unfiltered, measured with a PRBS 27-1 test pattern @1.25Gbps

Note 3) Measured at 1250 Mb/s with PRBS 27 – 1 NRZ test pattern for BER < 1x10⁻¹²



Pin Definitions and Functions

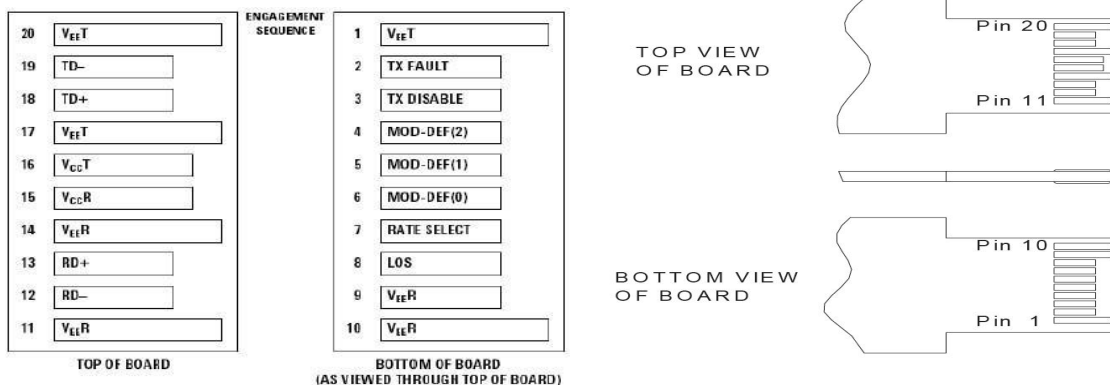

PIN #	Na	F	Note
1	Ve	Tx ground	
2	Tx Fault	Tx fault indication, Open Collector Output, active “H”	Note 1
3	Tx Disable	LVTTL Input, internal pull-up, Tx disabled on “H”	Note 2
4	MOD-DEF2	2 wire serial interface data input/output (SDA)	Note 3
5	MOD-DEF1	2 wire serial interface clock input (SCL)	Note 3
6	MOD-DEF0	Model present indication	Note 3
7	Rate select	No connection	
8	L	Rx loss of signal, Open Collector Output, active “H”	Note 4
9	V _{ee}	Rx ground	
1	V _{ee}	Rx ground	
1	V _{ee}	Rx ground	
1	R	Inverse received data out	Note 5
1	R	Received data out	Note 5
1	V _{ee}	Rx ground	
1	V _{cc}	Rx power supply	
1	V _c	Tx power supply	
1	Ve	Tx ground	
1	T	Transmit data in	Note 6
1	T	Inverse transmit data in	Note 6
2	Ve	Tx ground	

Note 1) When high, this output indicates a laser fault of some kind. Low indicates normal operation. And should be pulled up with a 4.7 – 10KΩ resistor on the host board.

Note 2) TX disable is an input that is used to shut down the transmitter optical output. It is pulled up within the module with a 4.7 – 10KΩ resistor. Its states are:



Low (0 – 0.8V): Transmitter on (>0.8, < 2.0V): Undefined
High (2.0V~Vcc+0.3V): Transmitter Disabled Open: Transmitter Disabled
Note 3) Mod-Def 0,1,2. These are the module definition pins. They should be pulled up with a 4.7K – 10KΩ resistor on the host board. The pull-up voltage shall be between 2.0V~Vcc+0.3V. Mod-Def 0 has been grounded by the module to indicate that the module is present
Mod-Def 1 is the clock line of two wire serial interface for serial ID
Mod-Def 2 is the data line of two wire serial interface for serial ID
Note 4) When high, this output indicates loss of signal (LOS). Low indicates normal operation.
Note 5) RD+/-: These are the differential receiver outputs. They are AC coupled 100Ω differential lines which should be terminated with 100Ω (differential) at the user SERDES. The AC coupling is done inside the module and is thus not required on the host board.
Note 6) TD+/-: These are the differential transmitter inputs. They are AC-coupled, differential lines with 100Ω differential termination inside the module. The AC coupling is done inside the module and is thus not required on the host board.

Typical Interface Circuit

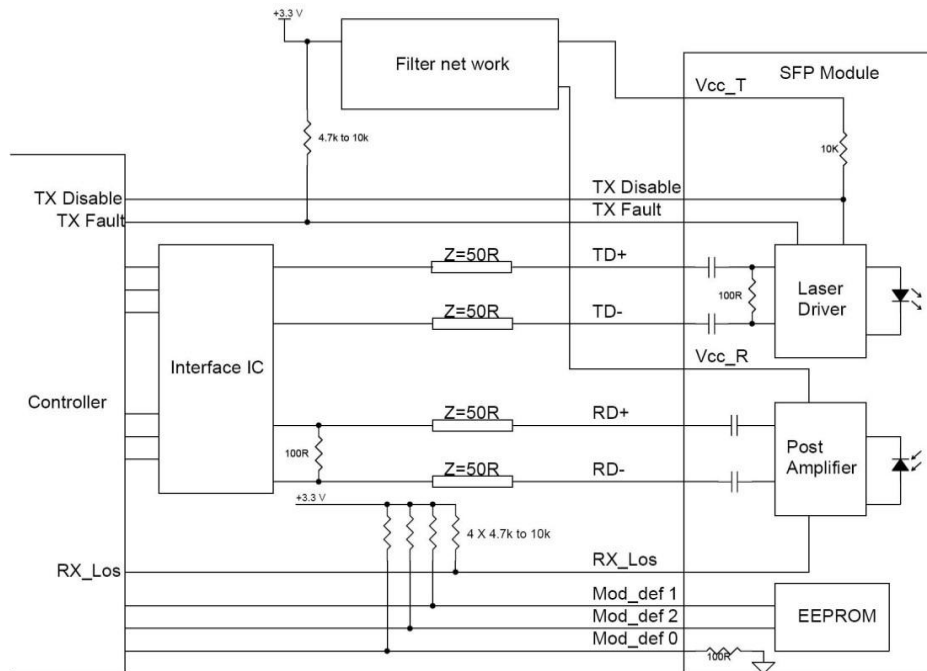



Recommended power supply filter

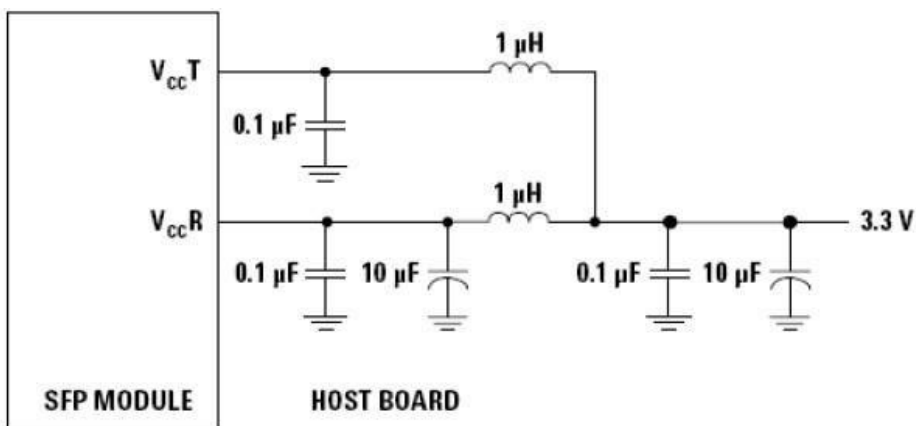

Note: Inductors with DC resistance of less than 1Ω should be used in order to maintain the required voltage at the SFP input pin with 3.3V supply voltage. When the recommended supply filtering network is used, hot plugging of the SFP transceiver module will result in an inrush current of no more than 30 mA greater than the steady state value.

Package Dimensions

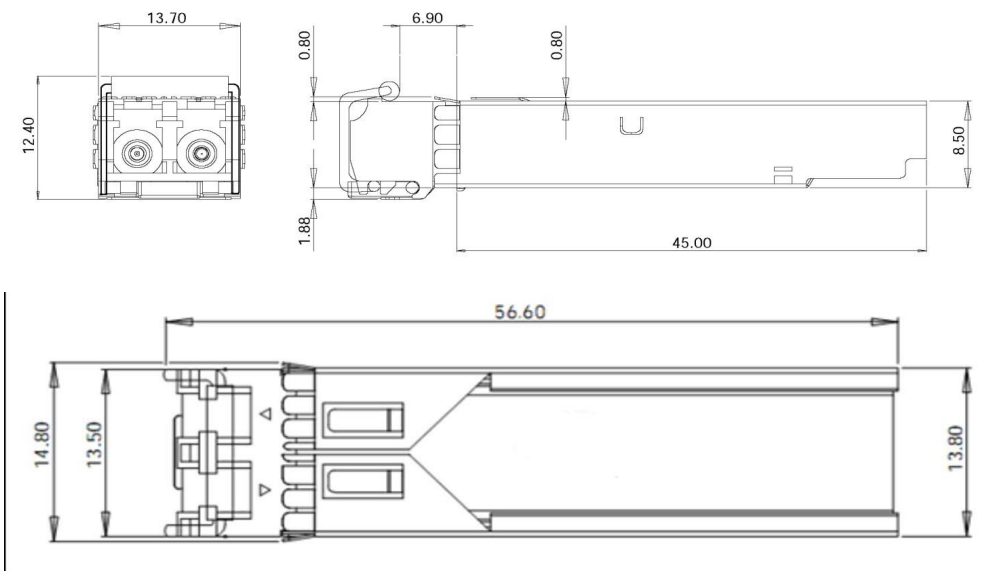



Ordering Information & Related Products

Product part Number	Data Rate (Mbps)	Media	Wavelength (nm)	Transmission Distance(km)	Temperature Range (Tcase) (°C)	
TOP-SFP-1.25G-80-c	1250	Single mode	1550	80	0~70	commercial
TOP-SFP-1.25G-80-e	1250	Single mode	1550	80	-10~80	extended
TOP-SFP-1.25G-80-i	1250	Single mode	1550	80	-45~85	industrial



TOPSTAR TECHNOLOGY INDUSTRIAL CO., LIMITED

Topstar Technology Industrial Co., Ltd

**Add: F5, Rongcheng Building, 28 Yayuan Road Wuhe Community,
BanTian Street, Shenzhen, China**

Tel: +86 755 8255 2969 Email: lisa@topsfp.com

Skype: [lisalin6565](https://www.skype.com/user/lisalin6565) Whatsapp: +86 13798265065

Wechat: 251081707

Facebook and Linked in: Topstar Technology Industrial Co., Ltd

