



TOPSTAR TECHNOLOGY INDUSTRIAL CO., LIMITED

# 产品规格书

## *Product Specification Sheet*

### TOP-SFP+-8.5G-LR

RoHS Compliant 8.5Gb/s SFP+ 1310nm 10km Optical Transceiver



E-mail: [csale@topsf.com](mailto:csale@topsf.com)





## **PRODUCT FEATURES**

- DFB transmitter, PIN photo-detector
- Duplex LC connector
- Metal enclosure, for lower EMI
- Class1 Laser International Safety Standard IEC-60825 compliant
- Up to10km transmission distance
- 2-wire interface for management
- Specification compliant with SFF-8472
- Single3.3Vpower supply
- Very low EMI and excellent ESD protection
- Case operating temperature range:0°Cto+70°C

## **APPLICATIONS**

- Compliance with Fiber Channel FC-P1-4 800-SM-LC-L
- Compliant with 8G, 4Gand, 2G Fiber Channel
- Complaint to SFP+MSA
- RoHS Compliant.



### FUNCTIONALDIAGRAM

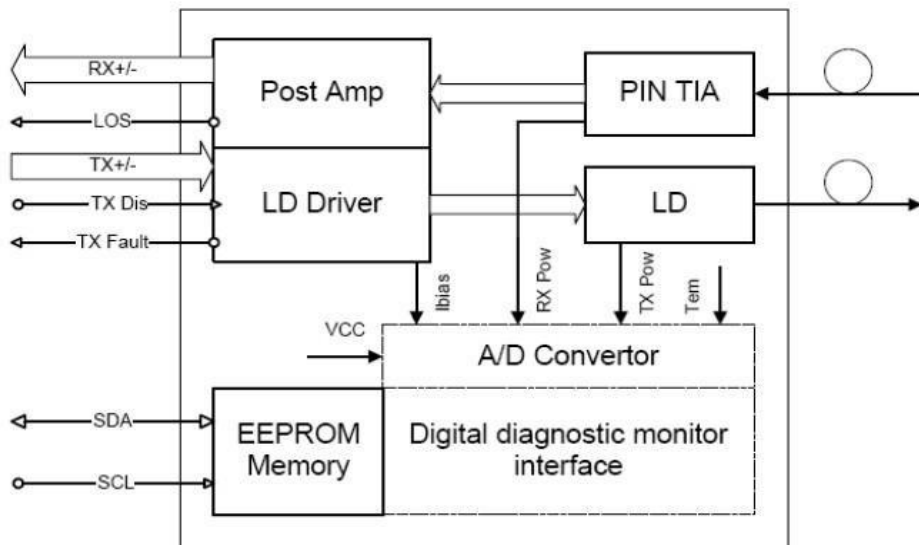

### ABSOLUTE MAXIMUM RATINGS

Parameter	Symbol	Min.	Max.	Unit	Note
SupplyVoltage	Vcc	-0.5	4.0	V	
StorageTemperature		-40	85	°C	
RelativeHumidity			85	%	

Note: Stress in excess of the maximum absolute ratings can cause permanent damage to the module

### GERERAL OPERATING CHARACTERISTICS

Parameter	Symbol	Min.	Typ	Max.	Unit	Note
DataRate	Ethernet		6.25		Gb/s	
	FiberChannel					
SupplyVoltage	Vcc	3.13	3.3	3.47	V	
	Vcc				V	
SupplyCurrent	Icc <sub>s</sub>				mA	
	Icc <sub>o</sub>			350	mA	
OperatingCaseTemp.	Tc	0		70	°C	



## ELECTRICAL INPUT/OUTPUT CHARACTERISTICS

### Transmitter

Parameter	Symbol	Min.	Typ	Max.	Unit	Note
Diff.inputvoltage swing		120		820	mVpp	1
TxDisableinput	H	VIH	2.0	Vcc+0.3	V	
	L	VIL	0	0.8		
TxFaultoutput	H	VOH	2.0	Vcc+0.3	V	2
	L	VOL	0	0.8		
InputDiff.Impedance	Zin		100		Ω	

### Receiver

Parameter	Symbol	Min.	Typ	Max.	Unit	Note
Diff.outputvoltage swing		340	650	800	mVpp	3
RxLOSOutput	H	VOH	2.0	Vcc+0.3	V	2
	L	VOL	0	0.8		

Note1)TD+/-are internally AC coupled with100Ω differential termination inside the module.

Note2)Tx Fault and RxLOS are open collector outputs, which should be pulled up with 4.7k to10kΩ

resistors on the host board. Pull up voltage between 2.0V and Vcc+0.3V.

Note3)RD+/- outputs are internally AC coupled, and should be terminated with100Ω(differential)at the user SERDES.

## OPTICAL CHARACTERISTICS

### Transmitter

Parameter	Symbol	Min.	Typ	Max.	Unit	Note
OperatingWavelength		1260		1355	nm	
Ave.outputpower(Enabled)	Po	-6.5		-1	dBm	1
ExtinctionRatio	ER	3.5			dB	1
RMS spectralwidth	Δλ			1	nm	
Rise/Falltime(20%~80%)	Tr/Tf			50	ps	2
Opticalmodulationamplitude	OMA	-6.2			dBm	
Dispersionpenalty				1	dB	
OutputOpticalEye	IEEE802.3-2005Compliant					

### Receiver

Parameter	Symbol	Min.	Typ	Max.	Unit	Note
OperatingWavelength		1270	1310	1610	nm	
Sensitivity	Psen			-14.4	dBm	3



<b>Min.overload</b>	Pimax	0.5			dBm	
<b>LOSAssert</b>	Pa	-30			dBm	
<b>LOSDe-assert</b>	Pd			-16	dBm	
<b>LOSHysteresis</b>	Pd-Pa	0.5		4	dB	

Note1)Class1Laser Safety per FDA/CDRH and IEC-825-1 regulations.

Note2)20%~80%

Note3)Measured with a PRBS231-1test pattern,@6.25Gb/s,BER<10-12.

### PIN DEFINITIONS AND FUNCTIONS

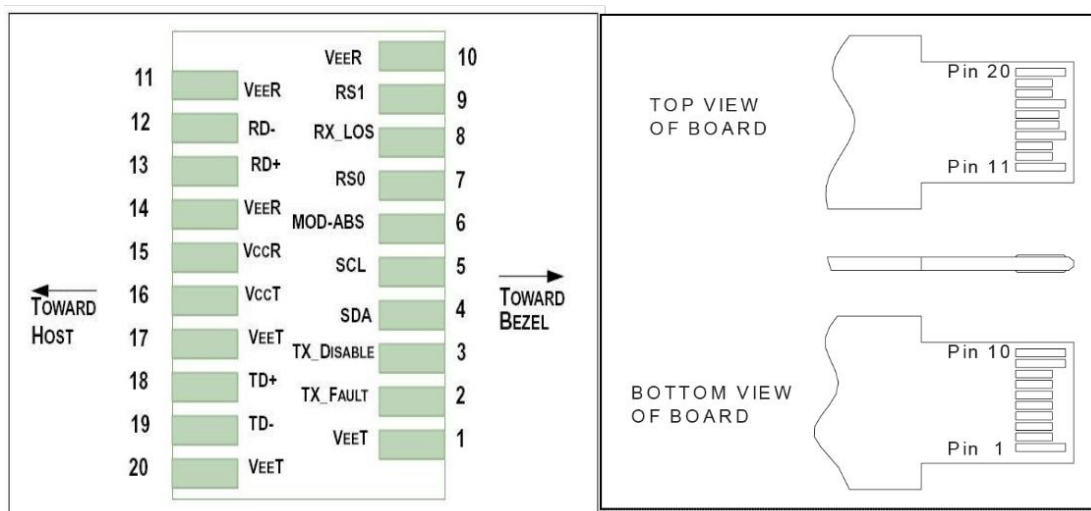



PIN #	Name	Function	Notes
1	VeeT	Module transmitter ground	Note 1
2	Tx Fault	Module transmitter fault	Note 2
3	Tx Disable	Transmitter Disable; Turns off transmitter laser output	Note 3
4	SDL	2 wire serial interface data input/output (SDA)	
5	SCL	2 wire serial interface clock input (SCL)	
6	MOD-ABS	Module Absent, connect to VeeR or VeeT in the module	Note 2
7	RS0	Rate select0,optionally control SFP+ receiver. When high, input data rate >4.5Gb/s,when low, input data rate <=4.5Gb/s	
8	LOS	Receiver Loss of Signal Indication	Note4
9	RS1	Rate select0,optionally control SFP+ transmitter. When high, input data rate >4.5Gb/s,when low, input data rate <=4.5Gb/s	
10	VeeR	Module receiver ground	Note 1
11	VeeR	Module receiver ground	Note 1
12	RD-	Receiver inverted data out put	
13	RD+	Receiver non-inverted data out put	
14	VeeR	Module receiver ground	Note 1
15	VccR	Module receiver 3.3V supply	
16	VccT	Module transmitter 3.3V supply	
17	VeeT	Module transmitter ground	Note 1
18	TD+	Transmitter inverted data out put	
19	TD-	Transmitter non-inverted data out put	
20	VeeT	Module transmitter ground	Note1

Note1)The module ground pins shall be isolated from the module case.

Note2)This pin is an open collector/drain output pin and shall be pulled up with 4.7K-10Kohmsto Host\_Vconthe host board.

Note3)This pin shall be pulled up with 4.7K-10Kohmsto VccT in the module.

Note4)This pin is an open collector/drain output pin and shall be pulled up with 4.7K-10Kohms to Host\_Vcon the host board. In FC designated as RX\_LOS, in SONET designated as LOS, and in Ethernet d esignated at Signal Detect.

### TYPICAL INTERFACE CIRCUIT

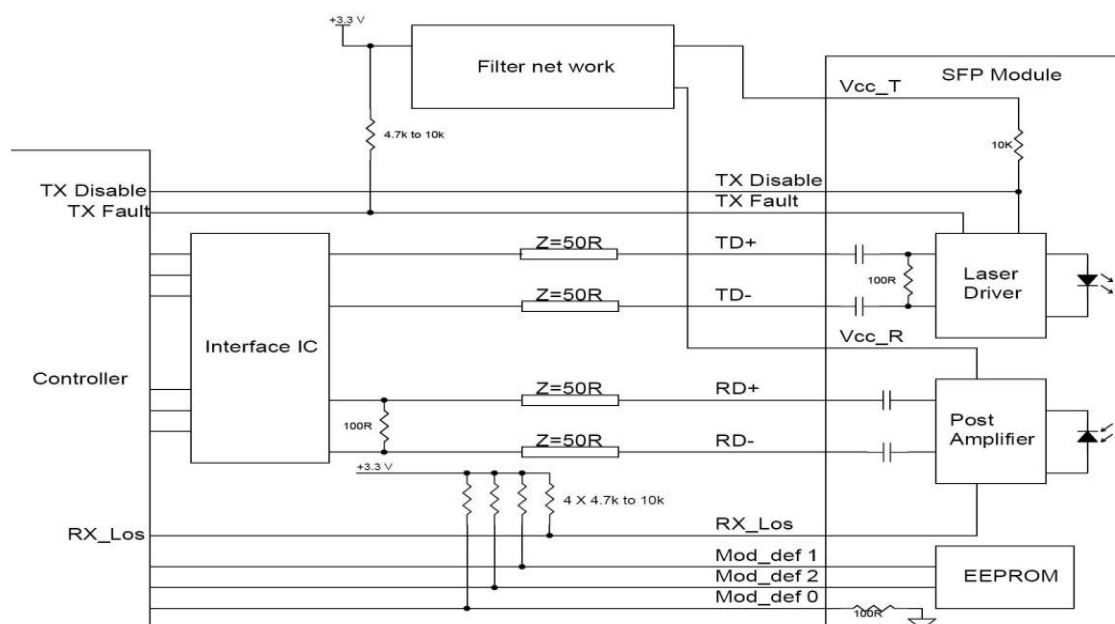



### Recommended power supply filter

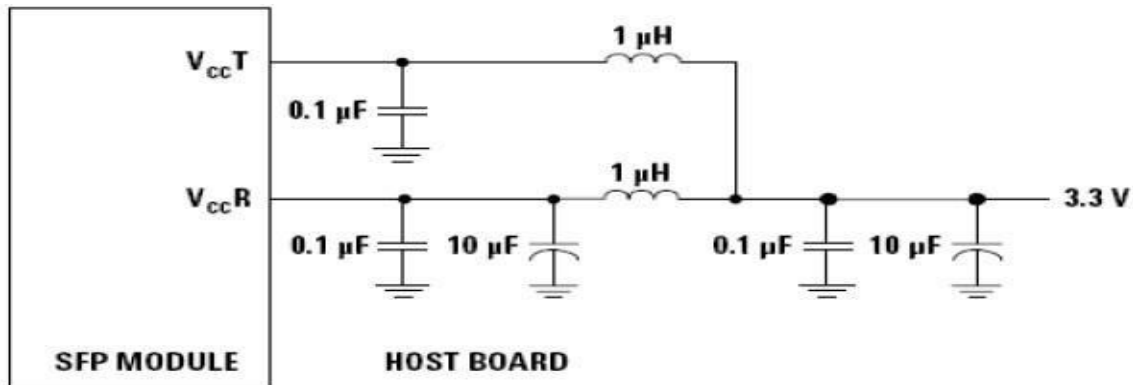

Note: Inductors with DC resistance of less than 1Ω should be used in order to maintain the required voltage at the SFP input pin with 3.3V supply voltage. When the recommended supply filtering network is used, hot plugging of the SFP transceiver module will result in an inrush current of no more than 30m A greater than the steady state value

### PACKAGE DIMENSION

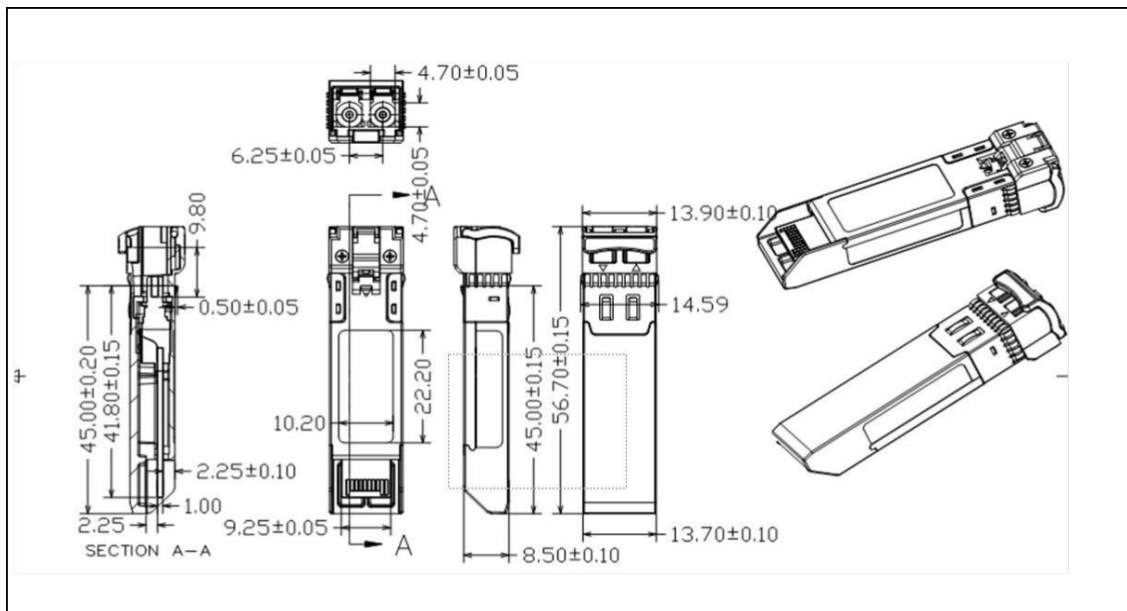



**TOPSTAR TECHNOLOGY INDUSTRIAL CO., LIMITED**

## **Topstar Technology Industrial Co., Ltd**

**Add: F5, Rongcheng Building, 28 Yayuan Road Wuhe Community,  
BanTian Street, Shenzhen, China**

**Tel: +86 755 8255 2969 Email: [lisa@topsfp.com](mailto:lisa@topsfp.com)**

**Skype: [lisalin6565](https://www.skype.com/people/lisalin6565) Whatsapp: +86 13798265065**

**Wechat: 251081707**

**Facebook and Linked in: Topstar Technology Industrial Co., Ltd**

